

**Dimond Roofing, a division of Fletcher Steel Limited, NZBN 9429037626563**

Contacts: Technical Advice **0800 766 377**

Sales and Supply **0800 346 663**

Website: <https://www.dimond.co.nz/>

Email: roofspec@dimond.co.nz

Address: 48 Victoria Street, Onehunga, Auckland 1061

Place of Manufacture

Aotearoa New Zealand

Technical Manual

<https://www.dimond.co.nz/downloads>

Product Description**1.1. Description**

Dimond long run roofing and wall cladding profiles are available in a variety of sheeting materials together with the appropriate fasteners, underlay, supporting netting, perimeter/penetration flashings and sealants. Roofing/cladding profiles are installed to the best practice and Dimonds technical manual to provide weather tightness and egress of moisture to residential or commercial buildings.

1.2. Product Variations (Thickness, Shape, and General Product Variables)

Refer to Table 2.1A, of the Dimond Technical Manual, which summarises the general sheeting material options available. Refer to the Dimond Technical Manual for specific information by profile. Please also refer to the Dimond Colour Chart for the full range of available colours in each of the paint coating types, (<https://www.dimond.co.nz/colour-range/standard-colours>)

1.3. Coating & Classes

Manufactured from materials supplied by Pacific Coil Coaters* and New Zealand Steel*.

- Galvsteel⁺ and Zinalume^{**} steel alloy produced in New Zealand.
- ZAM* (Zinc Aluminium Magnesium) steel alloy and Aluminium alloy ^{**} produced overseas.

Copper and Zinc are produced overseas.

GRP (Glass Reinforced Polyester) is produced in New Zealand.

Manufactured using different paint coatings available from Pacific Coilcoaters or New Zealand Steel depending on the durability required for the environment the roof or wall will be installed in, in accordance with AS/NZS 2728. For more information refer to Table 2.1C of the Dimond Technical Manual.

Refer to environmental literature available from Pacific Coilcoaters or New Zealand Steel or contact Dimond® Roofing on 0800 766 377.

Duraclad® is recommended for use in special areas such as fertiliser works or very severe marine.

Scope of Use**2.1 Recommend for use where:**

- Roof pitch meets the minimum required pitch for the selected product.
- Maximum purlin spacing does not exceed the wind uplift load from the product load span chart and is appropriate for the chosen service category for required foot traffic.
- Specify coating on steel to match the environment.
- Can be used as wall cladding either vertically or horizontally.

- Specify fixing type and length to be used with the correct purlin material
 - Ensure there is an allowance for thermal expansion on sheet lengths above 15m
 - Can be installed on top of cavibat ventilation batten
- (Refer to Dimond Technical Manual 2.1.4 for specific profile data)

2.2 Intended product use

Dimond long run roofing and wall cladding is intended to only be used on roof or wall constructions as the building envelop on either commercial or residential new or rebuild projects.

2.3 Limitations on use

Reference to sections below of the Dimond Technical Manual is required to ensure the expected system performance is achieved;

Dimond Technical Manual	Section Number
Roofing & Cladding Durability Information	2.1.1
Roofing and Cladding General Design	2.1.3
Specific Design by Profile	2.1.4
Roofing and Cladding Components	2.2
Installation Information	2.3

Compliance with the NZ Building Code

3.1 Compliance Statement and Applicable NZBC clauses

Past history of use of long run metal roofing and cladding products in New Zealand and information available from Pacific Coilcoaters and New Zealand Steel indicate that provided the system design, installation, use and maintenance is in line with the guidelines contained in the current Dimond Roofing technical literature and standards referenced therein, Dimond® Roofing long run metal roofing & wall cladding systems can reasonably be expected to meet the following performance criteria outlined in New Zealand Building Code;

- **B1 Structure: Performance clauses B1.3.1, B1.3.2, B1.3.3 (a) (b) (c) (g) (h), B1.3.4 (b) (d):** Dimond long run roofing and wall cladding has been tested in accordance with the NZMRM code of practice Section 17.1.
- **B2 Durability: Performance clauses B2.3.1(b):** Dimond long run roofing and wall cladding conforms to AS/NZS 2728 as stated in NZMRM code of practice section 17.4.
- **C3 Fire affecting areas beyond the fire source: Buildings C3.4(a):** Testing has been carried out material suppliers in accordance with the relevant standards stated in C3.4(a).
- **E2 External moisture: Performance E2.3.1, E2.3.2:** Is suitable for installation in accordance with Acceptable Solution E2/AS1, NZMRM code of practice, RANZ installation guides and Dimond installation Details/Technical Manual. Installation details provided by other parties such as architects and engineers may also be suitable.
- **F2 Hazardous building materials: Performance F2.3.1:** The quantities solid particles emitted by Dimond long run roofing and cladding, shall not give rise to harmful concentrations at the surface of the material where the material is exposed, or in the atmosphere.

Relevant Standards

- NZBC - E2/AS1 - External Moisture/building performance
- NZMRM Cop - NZ Metal Roof and Wall Cladding Code of Practice
- AS 1562.1:2018 - Sheet roof and wall cladding
- AS 4040.1,2 and 3-1992 - Methods of testing sheet roof and wall cladding resistance to concentrated loads, wind pressure for non-cyclone and cyclone regions
- AS/NZS 2728:2013 - Prefinished/prepainted sheet metal products for interior/exterior building applications - Performance requirements
- AS/NZS 1530.3:1999 - Methods for fire testing on building materials, components, and structures. Simultaneous determination of ignitability, flame propagation, heat, and smoke release
- AS/NZS 4020:2018 - Testing product for use with drinking water
- ISO 5660-1:2015 - Reaction to fire tests - Heat release. Smoke production and mass loss rate. Part 1
- ISO9223:2012 - Corrosion of metals and alloys - Corrosivity of atmospheres - Classification, determination, and estimation

Durability & Maintenance Requirements

4.1 Environments

Manufactured using different paint coatings and substrates for various environmental conditions depending on the durability requirements for each environment, subject to reference of suppliers literature, guidance from Dimond® and confirmation of warranty from Pacific Coilcoaters or New Zealand Steel.

For guidance, refer appropriate sections of the Dimond Technical Manual:

Dimond Technical Manual	Section Number
Environments	2.1.1.2

4.2

4.3 **Dimond® Roofing recycle** all metal scrap and offcuts which can then be reused in other metal based products. At the end of useful life metal roofing and cladding products can be recycled.

Durability & Maintenance guidelines

All roofing and cladding products are subject to the cumulative effect of weather, dust and other deposits. Normal rain washing will remove most accumulated atmospheric contaminants from roofs. For wall cladding, manual washing every 3 to 12 months, depending on the paint system, is recommended in moderate to very severe environments to prevent accumulation of dirt, debris or other material not removed by rain washing. For areas that do not receive any or adequate rain washing (called unwashed areas) such as soffits, wall cladding under eaves, underside of gutters, fascia's, sheltered areas of garage doors and unwashed roof areas, more extensive manual washing is required. Similarly other high-risk areas, around flues, under television aerials or overhanging trees and sites prone to mould, lichen, bird droppings or debris, need to have extensive manual washing.

All materials selected and supplied by Dimond® Roofing are warranted for external use only, to exceed the requirements of NZBC B.2.3 (1) for 15 years durability, providing the materials selected are suited to the environment and designed, detailed, and fixed and maintained in compliance with Dimond® Roofing instructions, the Roofing Code of Practice and good trade practice.

Refer appropriate sections of the Dimond Technical Manual.

Dimond Technical Manual	Section Number
Life Cycle Costing and Maintenance Options	2.1.1.4

Design

5.1 LT7 Profile

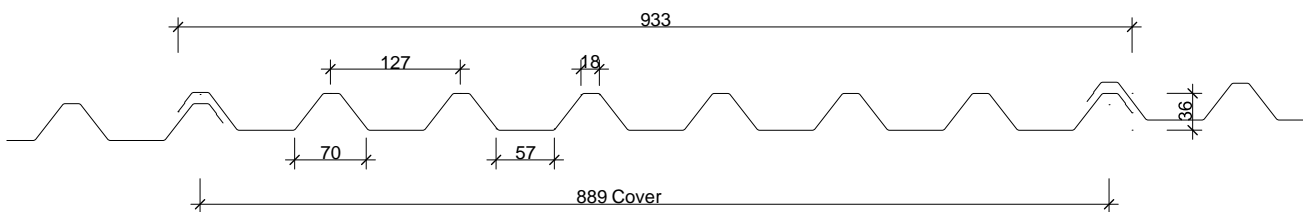

5.2 Specifications

Recommend use when:

- Roof pitch is 3° and above
- Max purlin spacing does not exceed wind uplift load from the LT7 load span charts
- Specify coating on steel to match the environment
- Can be used as wall cladding either vertical or horizontal
- Specify fixing type and length to be used with the correct purlin material
- Ensure there is an allowance for thermal expansion on sheet lengths above 20m
- Can be installed on top of cavibat ventilation batten

Product	Material	Thickness BMT (mm)	Roofing Max. Span End Span (m)*	Roofing Max. Span Internal (m)*	Walls Max. Span End Span (m)	Walls Max. Span Internal (m)
LT7 (min. pitch 3°)	Steel (G550)	0.40	1.20	1.80	1.60	2.40
		0.55	1.90	2.90	2.30	3.40

Aluminium (H36)	0.70	0.90	1.30	1.20	1.80
	0.90	1.50	2.30	1.90	2.80
Duraclad® (GRP)	1.70	0.80	1.20	1.30	2.00

Spans for roofing where the ultimate wind uplift load does not exceed 1.5 kPa.

Spans for walls are limited by an acceptable appearance or an ultimate wind uplift load of 2kPa.

*Restricted Access Roofing

*For more information, please refer to Dimond's website

5.3 LT7 Fastener Layout Options

Dimond LT7 Fastener Layout Options

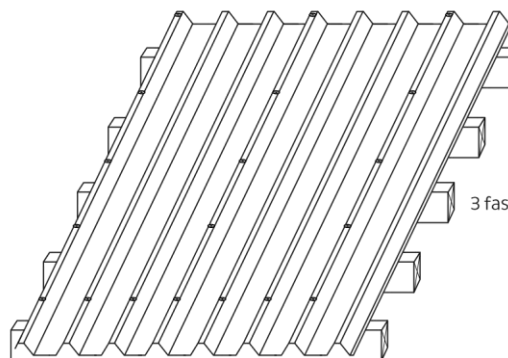
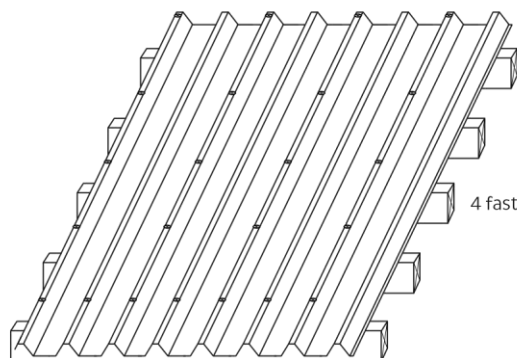

Can be installed over plastic cavibat battens.

For more information, please refer to Dimond® Roofing website <http://www.dimond.co.nz/products/lt7>

Installation and Construction Instructions

For installation instructions please refer to the sections of Dimonds Technical Manual Installation Guide references below or the links provided;

Dimond Technical Manual Installation Guide Reference	Section Number
Handling and Storage	2.3.1
Layout and fastening	2.3.2
Flashings	2.3.3
General Workmanship	2.3.4
Dimond CAD details	https://www.dimond.co.nz/downloads#drawings
Code of Practice	https://www.metalroofing.org.nz/cop/introduction

6.1 Warnings/Bans

Not subject to any warning or ban under section 26 of the Building Act 2004.

DISCLAIMER

As part of Dimond Roofing's policy of continuing product and system development, we reserve the right, at any time and without notice, to discontinue or change the products, materials, design advice, features or specifications represented in the technical literature without incurring any liability. The information in this document is issued for general application in New Zealand, and should not be treated as a substitute for detailed technical advice in relation to requirements for individual projects in New Zealand or overseas. To the extent permitted by law, Dimond Roofing disclaim any liability for loss or damage incurred by the use of the information in this document and any technical literature issued by Dimond Roofing unless it is covered by a specific warranty agreement. Dimond Roofing, a division of Fletcher Steel Ltd. November 2023.